

Battery Pack

ZB-B1800

ZB-B1800 is a portable power supply, safety measures were designed to protect against over-charge, discharge, over-current, and short-circuit. ZB-B1800 batteries pack is an ideal power supply for various portable applications.



Features

- Main application: Furniture
- Input voltage: 24 ~ 32V DC
- Input current: 0.6 ~ 3.0A
- Output voltage: 21 ~ 29V DC
- Output current: 3.0A
- Nominal voltage: 25.2V
- Over-current protection: 5A
- Short circuit protection
- Capacity: 1800mAH
- Color: Black
- Charge with switch mode power supply
- Operating ambient temperature: 0°C ~ +40°C
- Storage temperature: 0°C ~ +40°C
- Storage humidity: 20% ~ 85%

Dimensions

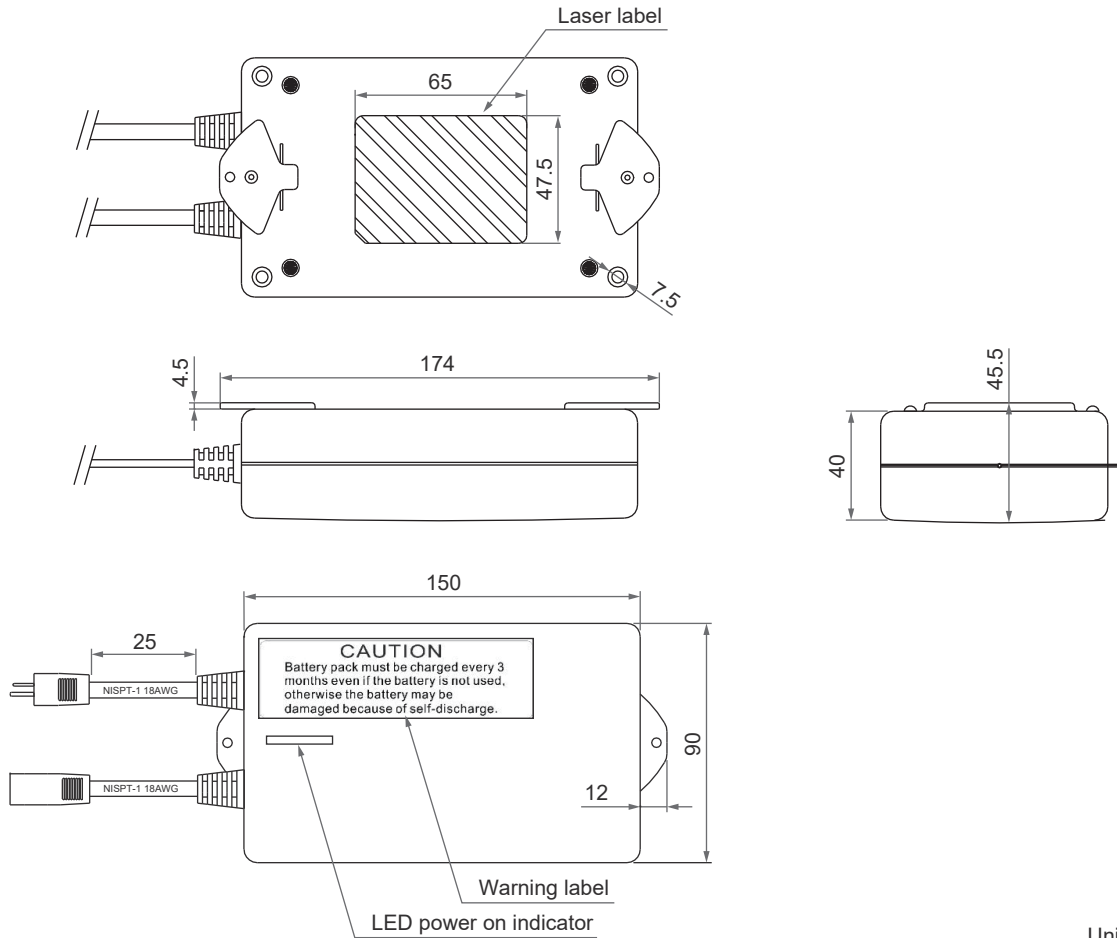

Unit: mm

Compatibility

Product	Model	Compatible requirement
Actuator	BD21, BD23, BD61, BD62, FD10, FD20, FD40, MD10	With Moteck direct-cut power cable DL1*
Power supply for charging	TSW1 switching mode power supply	29V DC/2A

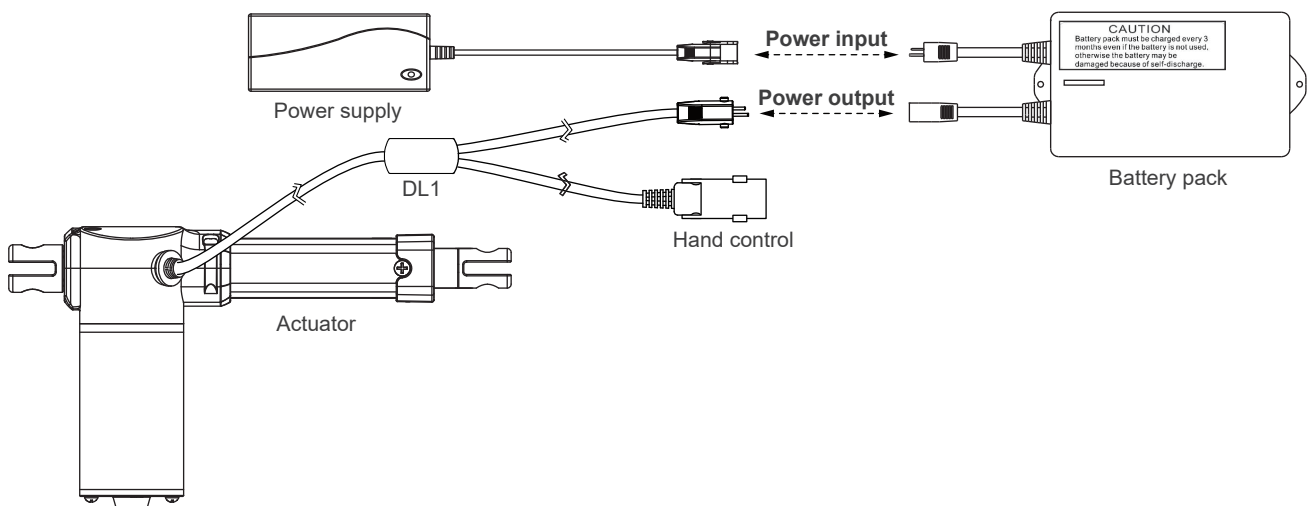

Remarks:

* Direct-cut power cable DL1 to connect to battery pack, without control box.

Function Description

Function	Description
Charging indication	During charging, the LED indicator will be flashing in red when the battery pack is <28.5V DC
	The LED indicator will turn green once the battery pack is fully charged.
Protection measure	The LED indicator will turn green once the battery pack is fully charged.
	The battery pack will not work if its voltage drops below 18V DC.
	If the current consumption reaches 5A, the battery pack will cut off the output voltage supply after 60 seconds. Peak current protection is set at 14A.
	There's short circuit protection for this battery pack.



- Please use the battery pack according to the specification mentioned in the datasheet.
- Please charge the battery at least every 50 days.
- For a brand new product, please connect it to a proper charger until the LED indicator turns red.
- The battery pack is fragile. Please handle with care, and keep it away from heat.

Terms of Use

The user is responsible for the suitability of MOTECK products, and the products listed on the MOTECK website are subject to change without notice. MOTECK reserves the right to terminate sales or delete any products displayed on the website or listed in its catalog.