

Hand Control H2B

H2B hand control is designed to function as a Direct-Cut system, it is able to connect with actuator directly, which makes up a simple system with a DC power supply and functions without a control box, suitable for furniture applications like recliner sofa and adjustable beds.



Features

- Main applications: Home care, furniture
- Max. motor number to control: 2
- Available number of buttons: 2, 4
- Color: Silver
- LED power on indicator
- With hook for easy placement
- Cable length: Total 1600mm long with 250mm spiral

Dimensions

Unit: mm

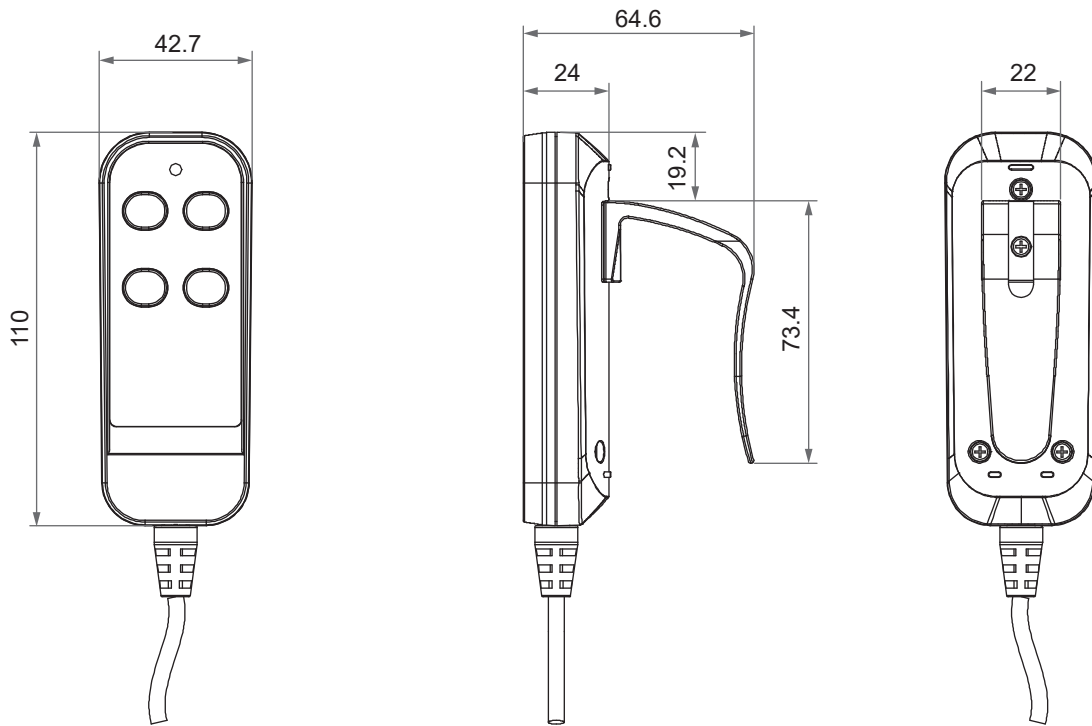

Standard Panel Artwork

Definition 1

Code	A	B
Artwork		
	H2B-02-1-A0U	H2B-04-2-B0U

Button definition 1:

- Artwork A, B

- ① Actuator #1 extends
- ② Actuator #1 retracts
- ③ Actuator #2 extends
- ④ Actuator #2 retracts

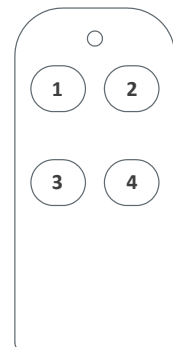

Compatibility

Product	Compatible models	Compatible requirement
Actuator	BD61, FD60, FD61	- With Moteck Direct-Cut cable DL2 or TL2.
	BD21, BD23, BD62, FD10, FD20, FD40, MD10, MK33	- With Moteck Direct-Cut cable DL1.
	FD20, FD40, BD62, MK33	- With Moteck Direct-Cut cable TL1.

Cable Plug



U-type (5-pin DIN plug)

Ordering Key

		H2B - 2 - 1 - B 0 U
Number of button	2: 2 buttons 4: 4 buttons	
Number of motor	1: 1 motor 2: 2 motors	
Panel artwork code	A, B (Refer to Standard Panel Artwork)	
Cable length	0: 1600mm in length with 250mm spiral	
Cable plug	U: Moteck U-type DIN plug	

Terms of Use

The user is responsible for application suitability of Moteck products. As ongoing improvement process continues, products listed on the Moteck website are subject to change without prior notice. Moteck reserves the right to terminate the sales or remove any product displayed on the website, or listed in its catalogues.