

Hand Control DP08

DP08 hand control is designed for lifting table. It not only features with 3-digit display for the height, but also supports position memory function that allows user to store up to 3 positions. Moreover, DP08 has optional USB charging port for 3C devices.



Features

- Main application: Furniture
- Available number of buttons: 6
- Number of memory positions: 3
- 3-digit LED display for height read-out and error code
- Color: Dark grey
- Cable length: 1500mm straight
- Optional USB charging port for 3C devices (Output 5V DC/1.5A)

Dimensions

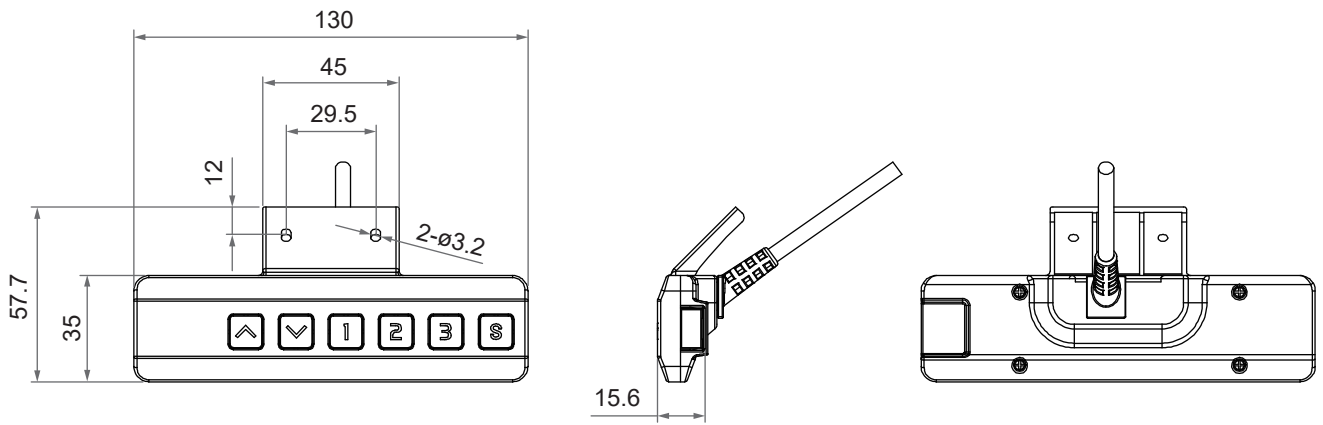

Without USB charging function

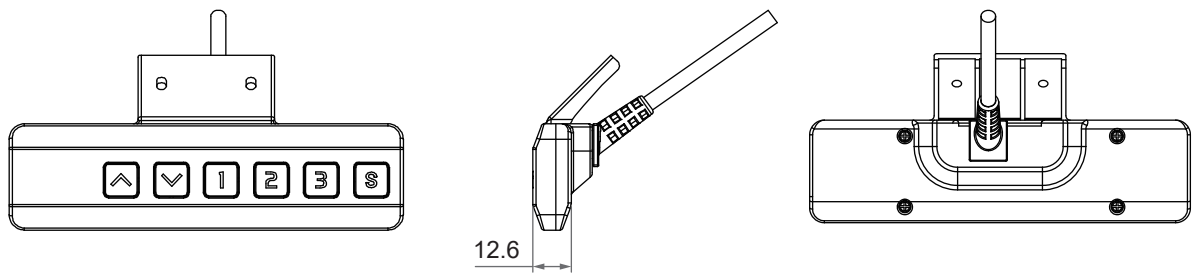

Unit: mm

Compatibility

Product	Model	DP08 spec
Control box	CF11D, CF13	With Moteck E2-type RJ plug (Fig. 1)

Cable plug



Fig.1 E2-type

Operating Guide

• Button Definitions:





-  Up
-  Down
-  Memory #1
-  Memory #2
-  Memory #3
-  Save / Setting









NOTE:

After installing the entire system correctly, you need to perform Auto Stroke Learning before you start using it. For more information about Auto Stroke Learning operation guide, please refer to control box product data sheet, which can be downloaded from the Moteck website.

• Operation

1. Press and hold button  , the actuator is extending, i.e. table is moving up.
2. Press and hold button  , the actuator is retracting, i.e. table is moving down.
3. Press and hold each button  ,  or  , table will move to the memorized position accordingly and stop automatically.

• Memory Setting

1. Press button  for 2 seconds until screen flashes. Followed by pressing button  , then screen will show  ; Release the button and the height read-out will be shown on screen and memorized as position 1.
2. The operation for memorize positions 2 and 3 and is similar to the one for position 1.
3. When the screen flashes after pressing button  for 2 seconds, if button  through  is not pressed within 20 seconds, the screen will stop flashing and leave the memory setting mode.

• Error Code

About error code information and recommended disposition, please refer to control box product data sheet, which can be downloaded from the Moteck website.

Ordering Key

DP08- 6 - U - 5

Button	6: 6 buttons
USB port	0: Without USB charging port U: 1x USB charging port
Cable length	5: 1500mm straight

Terms of Use

The user is responsible for application suitability of Moteck products. As ongoing improvement process continues, products listed on the Moteck website are subject to change without prior notice. Moteck reserves the right to terminate the sales or remove any product displayed on the website, or listed in its catalogues.