

Controller CI74



Supports Modbus RTU

CI74 is a controller suitable for industrial applications. It allows the customer's PLC/PC host controller to control the actuator using commands that comply with the Modbus RTU communication protocol through the RS-485 network. Each CI74 only controls one actuator, but multiple CI74s can be connected using the CAT-5 or higher network cables to form a multi-actuator control system, and the number of actuator groups can be added flexibly. The use of bus communication makes wiring brief, and because CI74 is widely compatible with Moteck's mainstream DC actuator models, it is possible to integrate simple DC actuators into the user's existing Modbus control network through CI74 control board.

Content

Features and Options	3
Function Version Options	4
System Diagram	5
Compatibility	6
Dimensions	7
1. PCBA only	7
2. DIN rail holder	7
Hardware I/O	8
1. Power input	9
2. Actuator connector	9
3. Supplementary control I/O	10
4. PC setting ports	11
5. Bus communication ports	12
Operation Indicator	13
Setting Switches	13
1. Lock / Unlock of setting function	13
2. Override	13
Precautions before Installation	14
Certifications	14
Ordering Key	15

Features and Options

- Main application: Industry
- Input voltage: 12~29V DC (same as actuator power output)
- Actuator power output: Same as input voltage
- Max. current: 16A
- Max. number of actuator: 1 channel
- Control platform: Modbus RTU communication protocol
- Function version: CI74-D / CI74-P / CI74-B, there are three model options.
(for CI74-P, the actuator's motion control can only be controlled through I/O terminals and cannot be controlled through Modbus messages; CI74-B is just the opposite and can only be controlled through Modbus messages.)
- Supports single Hall or dual Hall effect sensors (NPN type only) positioning feedback
- Support actuators with or without stroke limit switches
- Provides Moteck CI74 PC tool for setting parameters and control actuators
- 1500mm long USB to RJ45 PC setting cable (users must have at least one, please purchase separately.)
- LED operation indicator
- Duty cycle: 25%, max. 2 min. continuous operation in 8 min.
- Operating ambient temperature: -20°C~+55°C
- Storage ambient temperature: -40°C~+70°C
- Comes with 4 plastic PCB spacers
- Comes with a 100mm power cord
- Optional:
 - DIN rail holder (for mounting on DIN NS 32 or NS 35/7.5 rail)
 - 0.25W 120Ω terminating resistor (see p.11 for usage. Available for purchase as needed)
- Certified: CE Marking, EMC Directive 2014/30/EU.



Function Version Options

The primary control method of the CI74 is using the Modbus RTU communication protocol via the RS-485 serial communication port to receive and respond to commands from the PLC/PC master controller. In addition, individual actuators can be controlled offline through the [Supplementary control I/O] to facilitate system maintenance and repair work.

In terms of [Supplementary control I/O], the CI74 includes the following three function version options:

	CI74-D Direction Control & Absolute Position Output ⁽¹⁾	CI74-P Position Control & Arrival Signal Output ⁽²⁾	CI74-B Bus Control & Error Signal Output ⁽³⁾
Actuator extends	✓	-	-
Actuator retracts	✓	-	-
Analog position output	✓	✓	✓
5 or 10VDC output	✓	✓	✓
Position input	-	✓	-
Stop input	-	✓	✓
Position OK output	-	✓	-
Error output	-	-	✓
GND	✓	✓	✓
Learning	✓	✓	-

Notes:

- ⁽¹⁾ The offline control method of CI74-D receives analog input signals (extend/retract) from the [Supplementary control I/O] to individually control the actuator's movement direction. It outputs real-time position feedback, providing an analog signal that corresponds to the absolute position of the inner tube's movement.
- ⁽²⁾ The offline control method of CI74-P receives an input voltage of 0~10V DC (or 0~5V) from the [Supplementary control I/O], converting it into the target position for the actuator. If using a 10V range, a 5V input represents moving to 50% of the stroke. Once the target position is reached, a feedback signal is output.
- ⁽³⁾ CI74-B does not have an offline control method and can only be controlled via Modbus RTU commands through the RS-485 communication port. However, it can receive stop signal inputs from the [Supplementary control I/O] and output error signal when an error occurs.



System Diagram

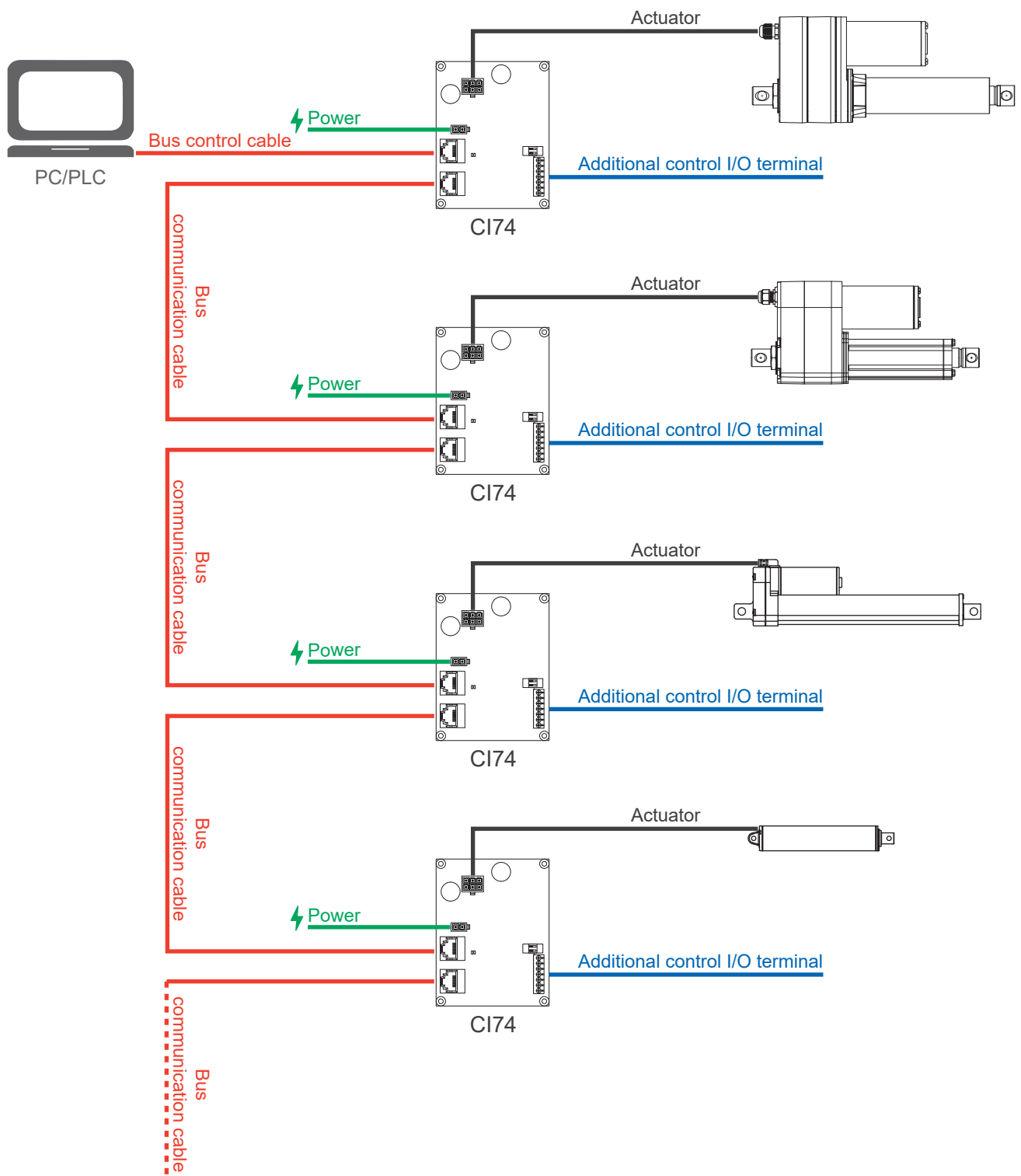

Compatibility

Actuator compatibility requirements:

- 12V DC or 24V DC motor, and the speed can be adjusted by input voltage.
- Control the actuator to extend and retract by swapping the DC input polarity.
- Either single Hall or dual Hall with positioning function.
 - (1) When used with the CI74 controller, the actuator count value must be greater than 100.
 - (2) Total Count = Total Stroke of the Actuator (mm) x Resolution (pulses/mm)
- Max. current <12.5A@24V DC / 16A@12V DC
- With a minifit 6-pin plug in the same wiring definition as the Moteck L3 type.



Dimensions

1. PCBA only (screw spacers included)

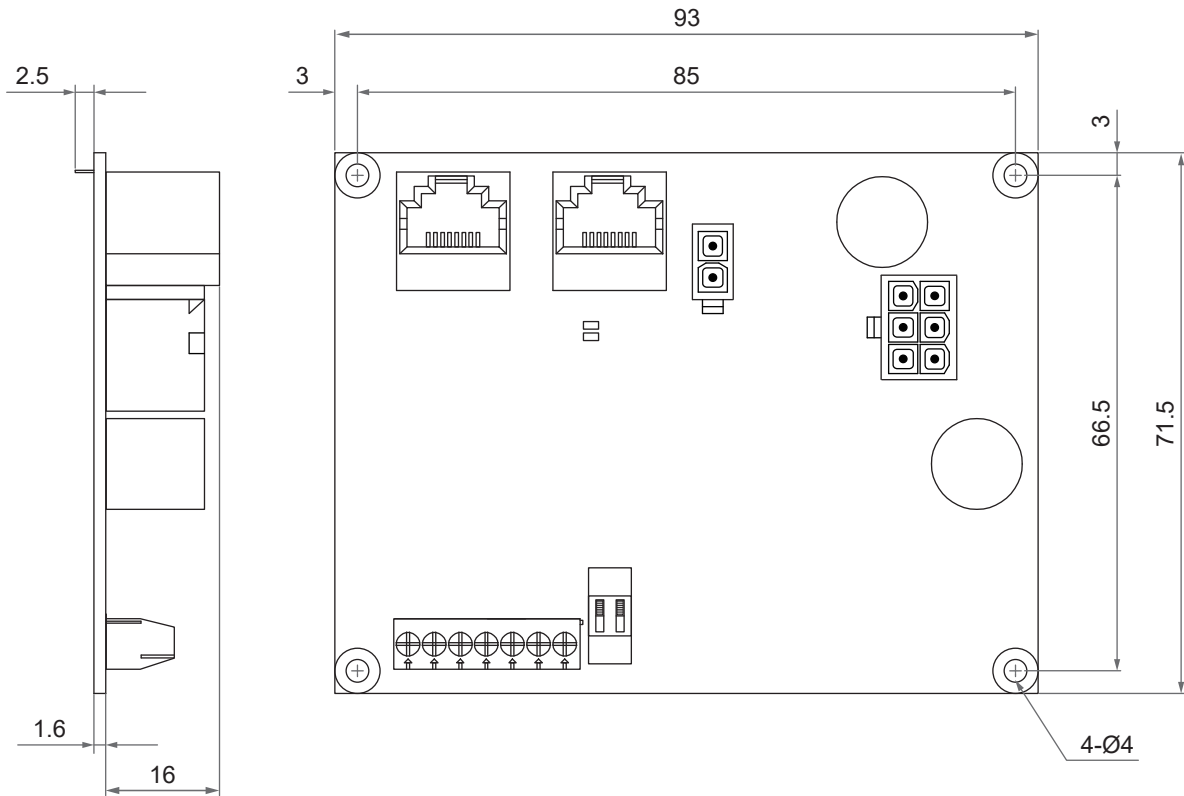

Unit: mm

Note: Comes with 4 plastic PCB spacers, M3 mechanical threaded screws not included.

2. DIN rail holder (Option)



Assembled by customer

Parts included:

- ① Foot element x2
- ② Side element x2 pcs and screw x4 pcs
- ③ Base x1 pc



Note: Also comes with 4 plastic PCB spacers.



Hardware I/O

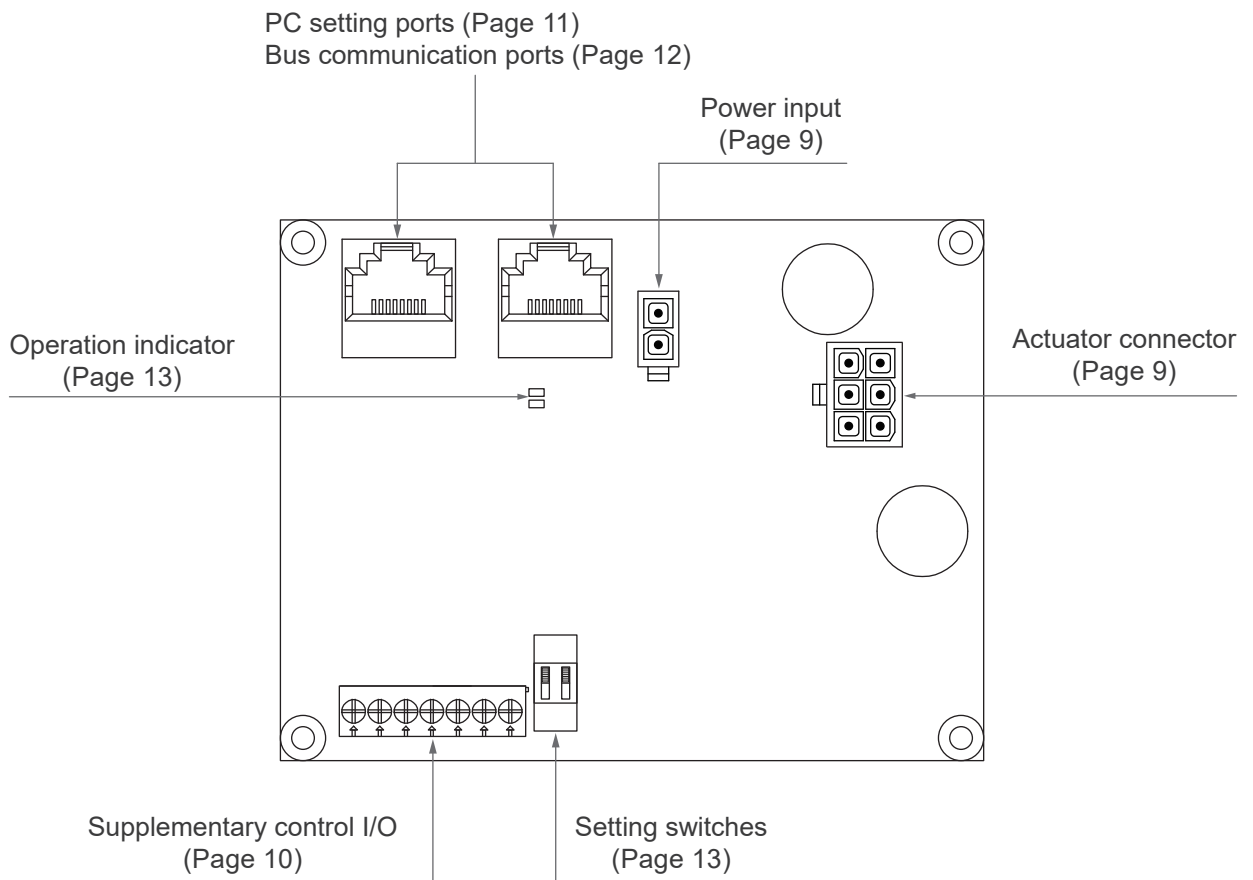

1. Power input

Definition	Description
V+	<ul style="list-style-type: none"> Nominal 24V DC (Acceptable input voltage range 22~25V DC) ; 12V DC (Acceptable input voltage range 11~13V DC) Recommend to use a 16AWG wire (Depending on the current)
V-	<ul style="list-style-type: none"> GND Recommend to use a 16AWG wire (Depending on the current)

Note:

The product comes with a short power cord that converts from a minifit plug to a 2-core flying lead. If necessary, users can arrange extended power wiring by themselves.

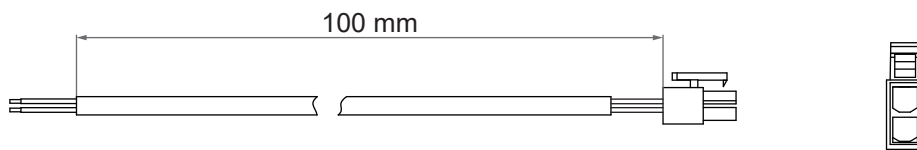

2. Actuator connector

Definition	Description	
M+	<ul style="list-style-type: none"> 24V DC output, 12.5A max ; 12V DC output, 16A max. 	
M-	<ul style="list-style-type: none"> When controlling the actuator to extend, M+/M- are VDC+/VDC- respectively. When retracting the actuator, the polarity is reversed. 	
G	GND	
Vcc	10V power output, for actuator's Hall module. Current max. 15mA	
H2	Hall 2 signal input	Signal phase diagram: (When actuator extends) <ul style="list-style-type: none"> A-type B-type <p>Both types are acceptable</p>
H1	Hall 1 signal input	

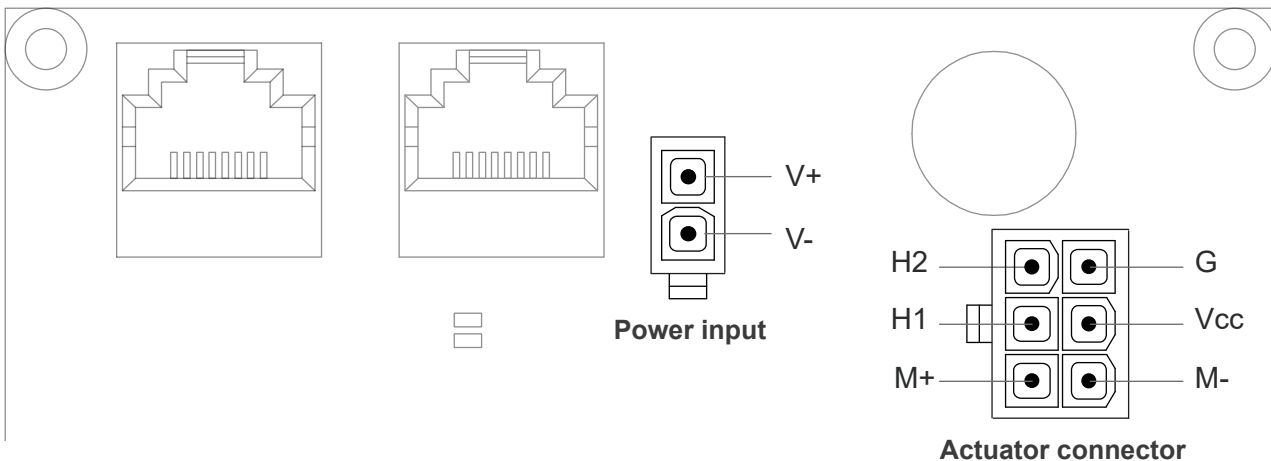

3. Supplementary control I/O

3.1 Options of CI74 control I/O

CI74 has three functional versions. The terminal definitions are as follows.

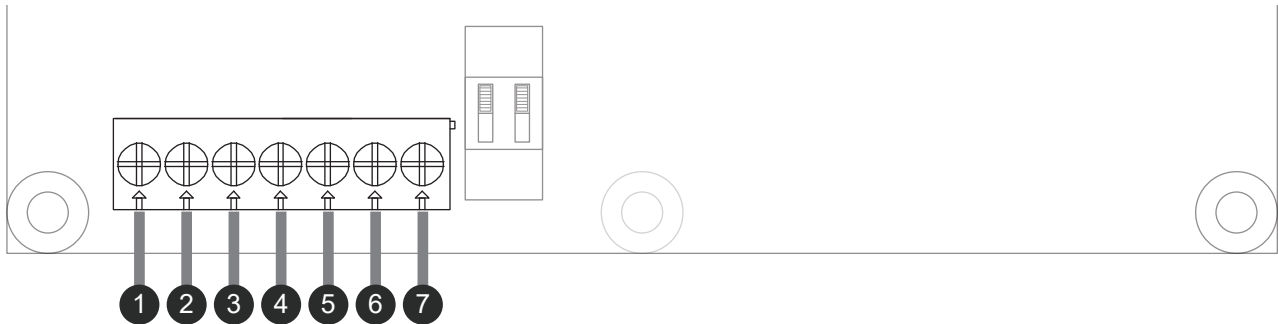

Pin No.	Function version		
	CI74-D Direction Control & Absolute Position Output	CI74-P Position Control & Arrival Signal Output	CI74-B Bus Control & Error Signal Output
①	Analog position output ⁽¹⁾	Analog position output ⁽¹⁾	Analog position output ⁽¹⁾
②	-	Reference voltage output ⁽²⁾	-
③	-	Analog position input ⁽³⁾	-
④	GND	GND	GND
⑤	Actuator retracts ⁽⁴⁾	Stop input ⁽⁵⁾	Stop input ⁽⁵⁾
⑥	Actuator extends ⁽⁴⁾	Position OK output ⁽⁶⁾	Error output ⁽⁷⁾
⑦	Learning ⁽⁸⁾	Learning ⁽⁸⁾	-

Notes:

- (1) Position output is an analog signal that reflects the actual moving position of the inner tube and is output in the form of DC voltage.
- (2) Power output can be used as the power supply for VR. There are two voltage specifications, which can be selected and set in the PC: 5 VDC or 10 VDC, max. 15mA
- (3) Position input: Input voltage makes the actuator run to the specified position, max. 10VDC input (Factory preset evenly distribute 0~10V to the full stroke defined by the software limits)
- (4) Dir. In/Dir. Out: Connect Pin ⑤ to Pin ④ (GND) to retract the actuator. And connect Pin ⑥ to Pin ④ (GND) to extend the actuator.
- (5) Stop input: The potential level is 'Normally High'. While Pin ⑤ is connected to Pin ④ (GND), it can be used as an signal input to stop the actuator.
- (6) Position OK output: It is Low potential (0 VDC) when moving, and High potential (3.3 VDC) when it is stopped and in position.
- (7) Error output: Normally at Low potential (0 VDC), it will become High potential (3.3 VDC) when an error occurs.
- (8) Learning:
 - CI74-D and CI74-P can directly trigger stroke learning by connecting Pin ⑦ to Pin ④ (GND) of the supplementary control terminal.
 - CI74-B cannot trigger stroke learning from the hardware. It can only be executed from the MOTECK CI74 PC tool or through Bus commands.



3.2 Behavior of Stroke Learning Function

When CI74 is performing stroke learning function, it will detect the limit position of the actuator, and the LED indicator will flash slowly at this time. (ON 1 second → OFF 1 second → ... Intermittent).
 If the actuator is equipped with physical limit switches, the above reference position will be the software limit position learned;
 If the actuator is not equipped with physical limit switches, after learning, it will retract 1% from the above-mentioned front reference position as the software limit position. The system will use the learned starting point as the stroke end limit in the retraction direction.

4. PC setting ports



Before using each CI74 for the first time, it is necessary to connect it to a PC using the PC setting cable for setting, and use the PC tool program provided by our company to complete the electronic installation and parameter setting (see manual) before connecting to the host controller to start using it.

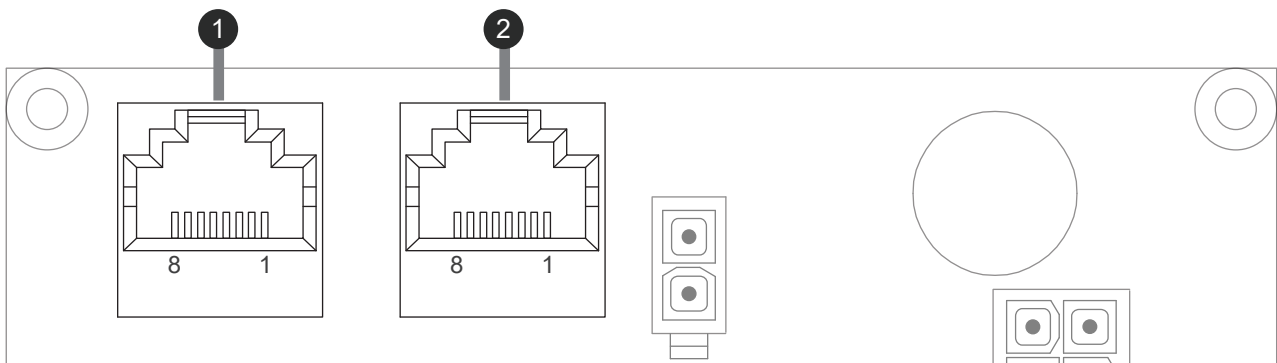

• Wire definition

Pin No.	8	7	6	5	4	3	2	1
Definition	Not used						RS485_A	RS485_B

• Connect to PC

Use a 1500mm long USB to RJ45 PC setting cable (Fig. 1), RJ45 is connected to the CI74 (port ① or ②), and USB is connected to the PC.
 To purchase separately according to your needs, please consult MOTECK sales representatives.



Fig. 1 PC setting cable



5. Bus communication ports

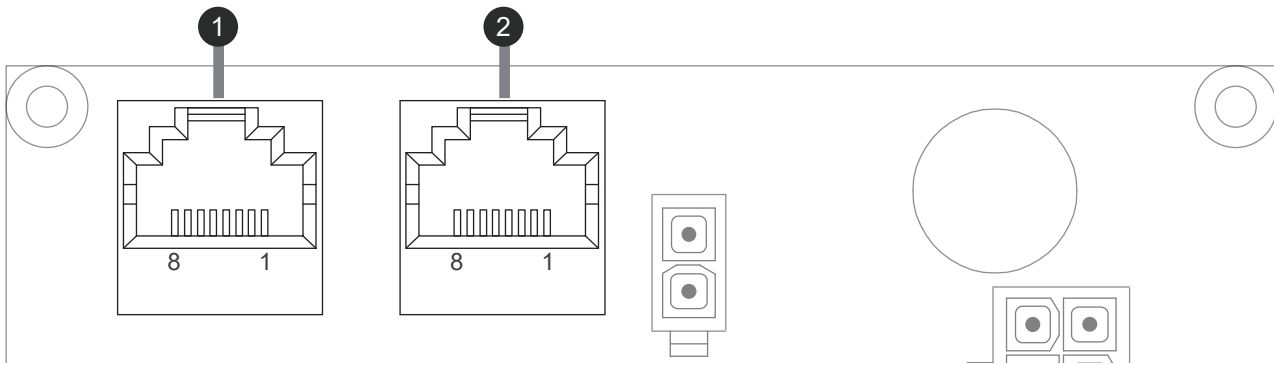

• Wire definition

Pin No.	8	7	6	5	4	3	2	1
Definition	Not used						RS485_A	RS485_B

• Connect to Modbus network

- (1) Connect each CI74 in series with CAT-5 (or above) communication cables with RJ45 connectors. Cables are prepared by customers.
- (2) If the CI74 is connected in series in a non-daisy chain topology, it is recommended to connect the first RJ45 (port ①) of the CI74.







- (1) Users are required to add terminating resistors at both ends of the Modbus trunk cable, which can effectively reduce reflections at the ends of the RS485 cable and reduce electrical noise interference. It is recommended to use a 120Ω resistor. If the end of the trunk cable happens to be a piece of CI74, you can use a commercially available terminating resistor (as shown in Figure 1, the resistor must be connected across Pin 1 & 2) and insert it into any of the two RJ45 sockets of the CI74. This accessory can also be purchased from our company, please contact your Moteck sales window.
- (2) It is theoretically possible to tap short branch lines from the bus trunk to connect additional devices, but it's not recommended to connect the CI74 to the bus in this way. However, if necessary, users can arrange to connect the RS485_A and RS485_B wires to the bus trunk according to the wiring definitions. With this connection method, terminating resistors are not required on the CI74 board. To minimize the impact of signal reflection, keep branch wires as short as possible and limit their number.



Fig. 1 Terminating resistor





Operation Indicator



Operation indicator		Description
	Green indicator stays on	Actuator reaches the upper and lower endstop switches
	Blinks green slowly	Learning
	Red indicator stays on	Power-on
	Blinks red slowly	Override

Setting Switches

1. Switch of communication speed (baud rate)

Parameters	Set	DIP switch
The available communication speed will be forced to 115200 baud (Bd), regardless of any parameters previously written to this CI74.	ON	
The communication speed is determined by the baud rate parameter written last time.	OFF	

2. Override

Parameters	Set	DIP switch
Disconnected from Modbus control	ON	
Connected to Modbus control	OFF	

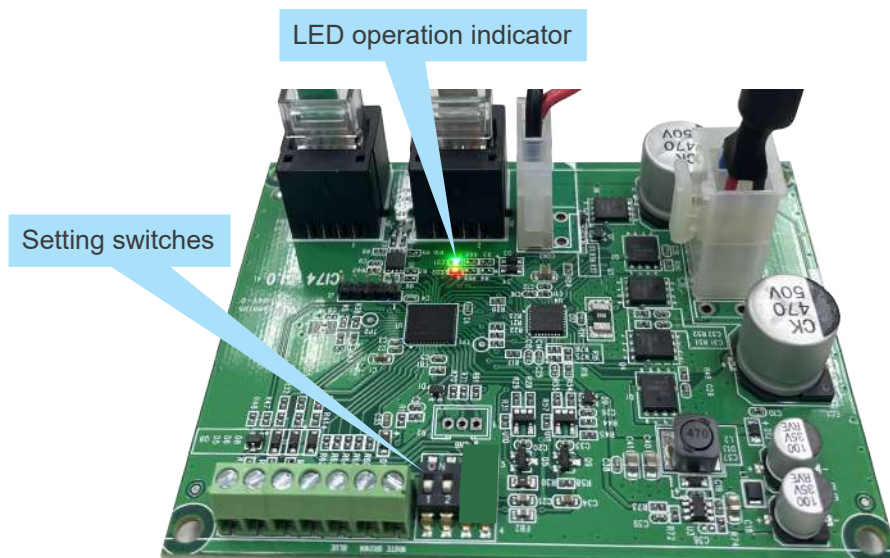

Precautions before Installation



- (1) Before using each CI74 for the first time, be sure to turn on the parameter setting switch according to the actuator specifications (see Setting Switches), then use the PC setting cable to connect to the PC for setting, and use the PC tool program provided by our company to complete the electronic installation and parameter setting (see manual) before connecting to the host controller to start using it.
- (2) Each CI74 only controls one actuator that is directly connected to it. Each CI74 in a multi-actuator control system is independent of each other, so the connected actuators are also independent of each other. It is not limited to whether they are the same model, specification, or size.
- (3) The actuator does not have to be equipped with a physical limit switch, but the software must be set correctly on the CI74 to be connected.
- (4) Retract all actuators to the end before installation.
- (5) After connecting the individual actuator to the assigned CI74, electronic installation, and [Learning for actuator stroke] steps must be completed before its movement can be tested.
- (6) During a power outage to the CI74, as long as the actuator has not been replaced or moved, there is no need to relearn the stroke. If the CI74 is replaced, please follow the installation steps to reset the CI74, but it has nothing to do with the settings of other CI74 in the system.
- (7) Prepare a 12 or 24VDC power supply with sufficient power according to the specifications and quantity of actuators.

Certifications

CI74 controller is compliant with the following regulations, in terms of the essential conformity requirements of EMC Directive of 2014/30/EU.

Emission	Immunity
EN IEC 61000-6-4:2019 BS EN IEC 61000-6-4:2019	EN IEC 61000-6-2:2019 BS EN IEC 61000-6-2:2019



Ordering Key

CI74- D - 0

Function version	D: Direction Control & Absolute Position Output P: Position Control & Arrival Signal Output B: Bus Control & Error Signal Output
Mounting	0: PCBA only R: With DIN rail holder



For more information about installation and use, please contact Moteck sales for information.

Terms of Use

The user is responsible for application suitability of Moteck products. As ongoing improvement process continues, products listed on the Moteck website are subject to change without prior notice. Moteck reserves the right to terminate the sales or remove any product displayed on the website, or listed in its catalogues.

