

Controller CI72

CI72 is a multi-functional and multi-purpose industrial control board that supports 2 MOTECK industrial actuators for synchronous applications.

CI72 can be setting to switch control mode or position input mode and other adjustable parameters by the user through DIP switches directly, without additional device connected.



Features and Options

- Main application: Industry
- Input voltage: Nominal 12/24V DC (acceptable input voltage range 9V ~ 32V DC) *
- Number of actuators to control: Max. 2 (synchronous move)
- Max. current limit: 25A (each actuator)
- Use the DIP switch to set the following function parameters:
 - Select switch control mode or position input mode (analog signal)
 - Select single actuator or 2 actuators
 - Support POT or Hall sensor (NPN type only) positioning feedback
 - Four-levels adjustable soft start/stop
- 2.0A ~ 25A ten-levels adjustable over-current protection setting (2 actuators are the same)
- Duty cycle:
 - 2 x 20A at 15% duty cycle, max. 40 sec. continuous operation in 4.5 min.
 - 2 x 10A at 40% duty cycle, max. 2 min. continuous operation in 5 min.
- Operating ambient temperature: -20°C ~ +55°C
- Certified: CE Marking, EMC Directive 2014/30/EU
- Option: Mounting kit (for mounting on DIN NS 32 or NS 35/7.5 rail)

Dimensions

PCBA only

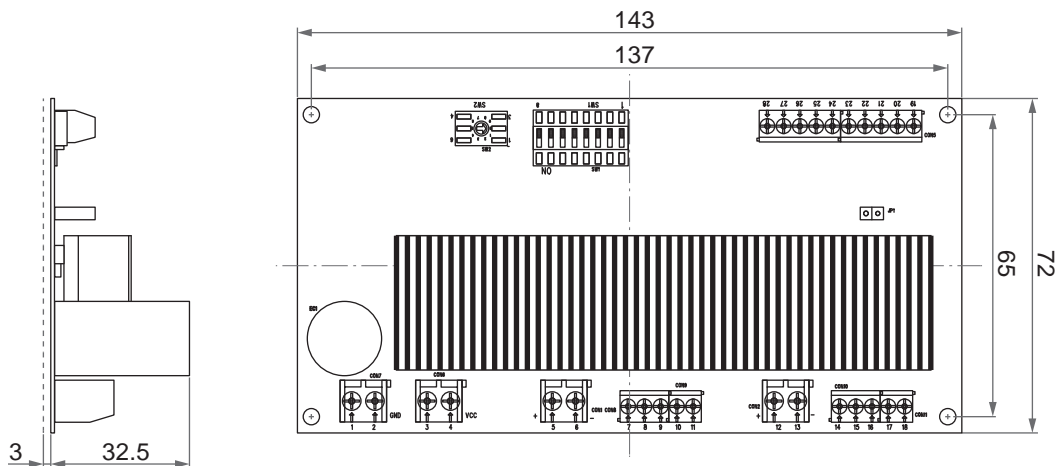

Unit: mm

Mounting kit (Option)



Assembled by customer:

- ① Foot element x2 pcs
- ② Side element x2 pcs
- ③ Base x1 pc



After installation



Compatibility

Actuator compatibility requirements:

- 12V DC or 24V DC motor, and the speed can be adjusted by input voltage.
- Control the actuator to extend and retract by swapping the DC input polarity.
- Synchronous control requires the actuator to have a positioning function of POT, single Hall or dual Hall.
- If the actuators have no positioning function, they must have the stroke limit switches at both ends to stop by themselves.

Interface Guide



- Pay attention to insulation protection during installation to avoid possible risks and hazards for users to touch.
- Please confirm the actuator specification before connecting, and fix the actuator with appropriate mechanical installation.

1. Switches and terminals

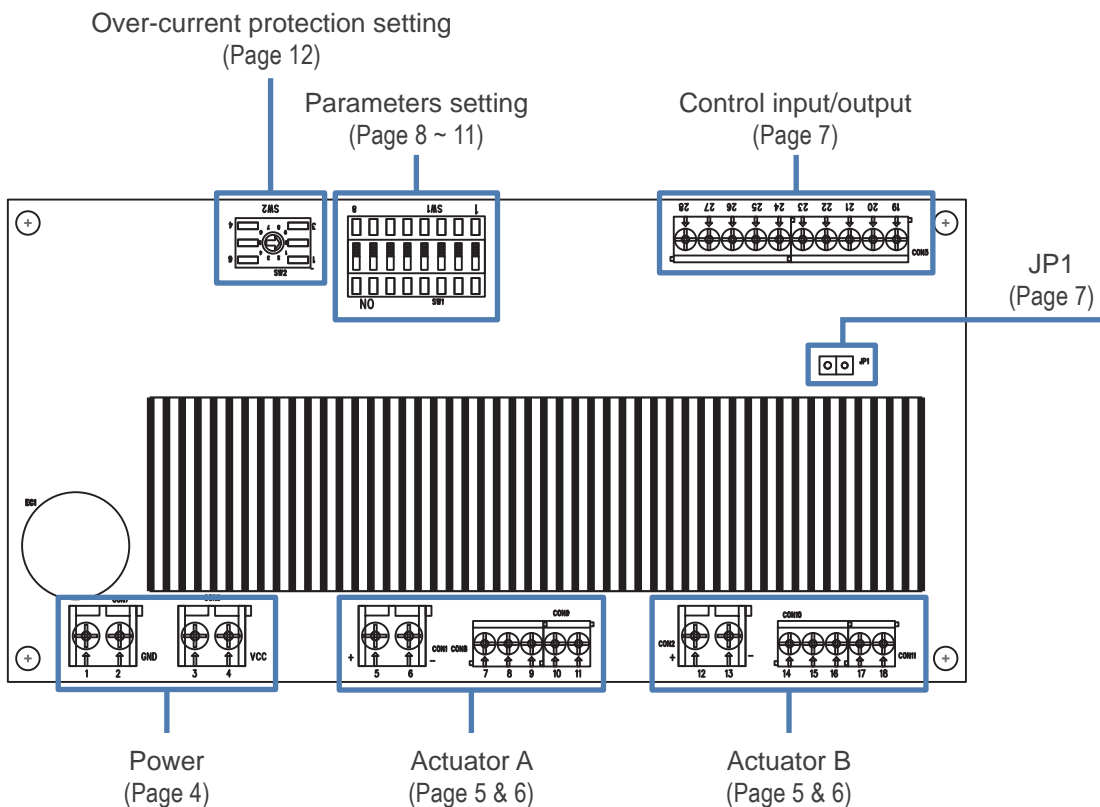

2. Power input

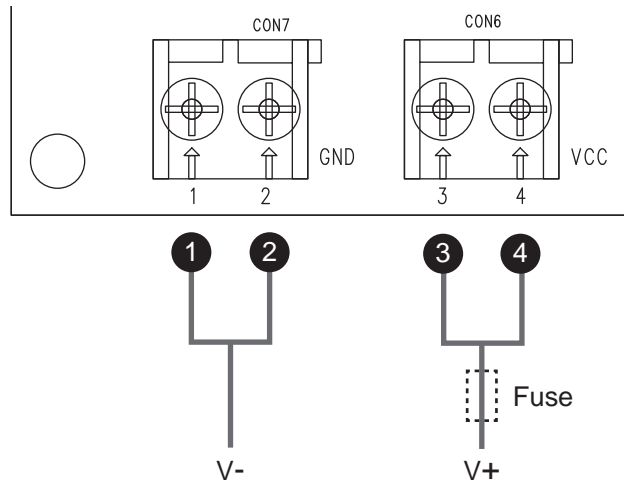

Port	Definition	Description
①	V-	<ul style="list-style-type: none"> • GND • For each terminal, the allowable maximum cross-sectional area of the copper wire is 3.3mm² (12AWG)
②		
③	V+	<ul style="list-style-type: none"> • Nominal 12/24V DC (acceptable input voltage range 9V ~ 32V DC) • For each terminal, the allowable maximum cross-sectional area of the copper wire is 3.3mm² (12AWG)
④		

Remarks:

- (1) Install a slow-blow fuse between CI72 and the power supply for protection.
The fuse is connected by the customer. The recommended specification is 50A Max.
- (2) In order to avoid malfunctions caused by voltage drop, the cross-sectional area of the power cord must be large enough, and the wire length from the power supply to the control board and from the control board to the actuator motor is as short as possible, and it is recommended not to exceed 1 meter. If the total load current is less than 30A, a single wire with a cross-sectional area of 3.3mm² (12AWG) can be used. If the total load current is as high as 30A ~ 50A, it is recommended to use two wires with a cross-sectional area of 2.0mm² (14AWG) or more in parallel.



- When the actuator starts, an inrush current will be generated for about 0.2 seconds, the starting inrush current of actuator is as high as 3 times the typical current of the actuator's maximum load.
- If a power supply is used, the specification must be sufficient to withstand the inrush current when the customer uses the maximum load. Inrush current won't be a problem if you're using a battery as your power source. Besides, the connectors, switches, and relays used in the customer's system must also be sized to withstand the inrush current.
- It is forbidden to use PWM power input or to adjust the input voltage in an attempt to control the speed of the connected actuators.

3. Actuators terminals

- With Hall effect sensor

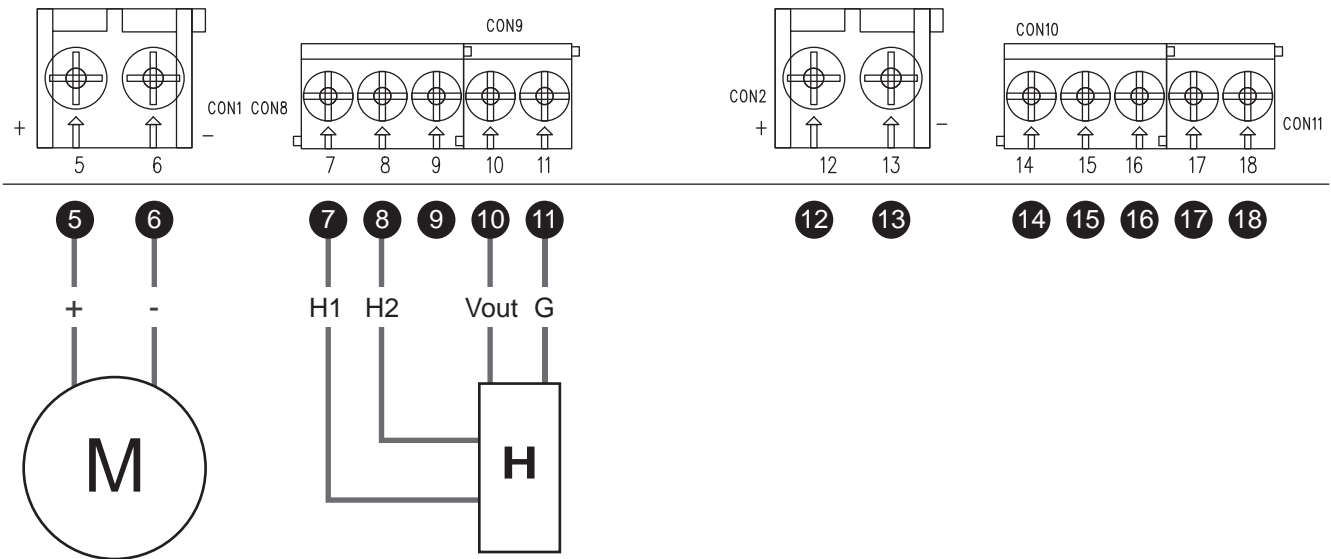

Port		Definition	Description
5	12	M+	12V or 24V DC output. When controlling the actuator to extend, M+ / M- are VDC+ / VDC- respectively. When retracting the actuator, the polarity is reversed.
6	13	M-	
7	14	H1	Hall 1 input Hall signal data: Actuator extends Both types are acceptable
8	15	H2	
10	17	Vout	5V power output, for actuator's Hall module. Current max. 20mA.
11	18	G	GND

Remarks:

- (1) For port 5 6 12 13, the recommended cross-sectional area of each copper wire is $0.5\text{mm}^2 \sim 3.3\text{mm}^2$ (20AWG ~ 12AWG)
- (2) For port 7 ~ 11, 14 ~ 18, the recommended cross-sectional area of each copper wire is $0.2\text{mm}^2 \sim 0.83\text{mm}^2$ (24AWG ~ 18AWG).
- (3) For single actuator mode, please use only terminals 5 ~ 11.
- (4) For single Hall sensor actuator, please use only terminals 7 and 14 (Hall 1).

• With Potentiometer

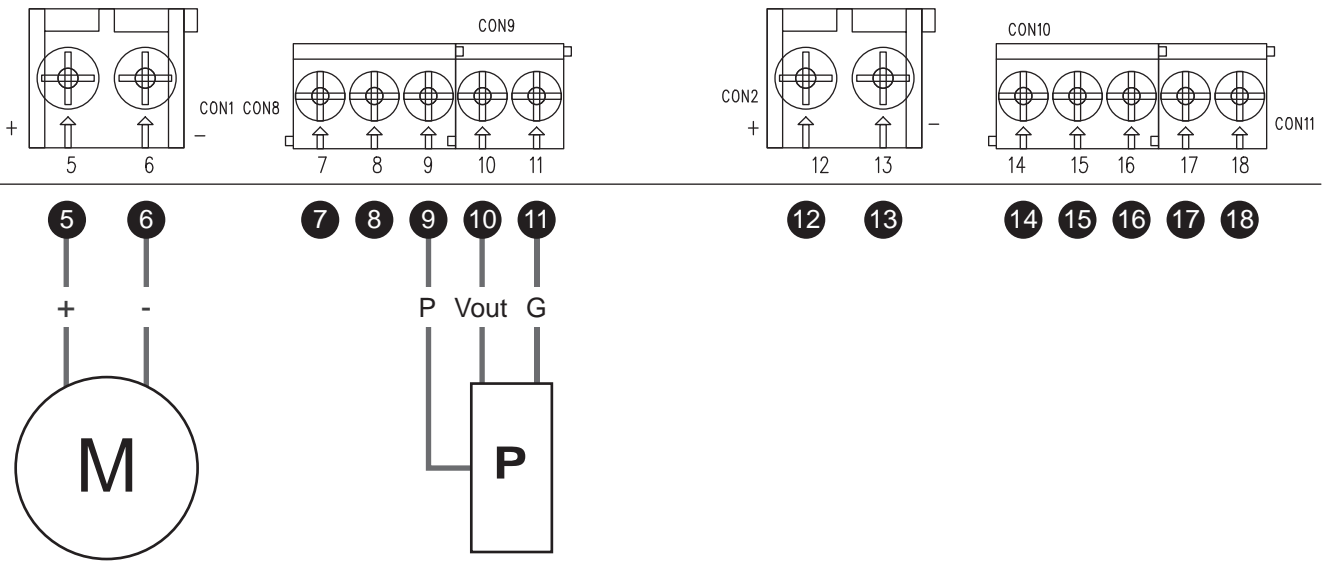

Port		Definition	Description
5	12	M+	12V or 24V DC output. When controlling the actuator to extend, M+ / M- are VDC+ / VDC- respectively. When retracting the actuator, the polarity is reversed.
6	13	M-	
9	16	P	Voltage (POT value) input <div style="border: 1px solid black; padding: 5px; width: fit-content; margin: 5px auto;"> <p>Wiring:</p> </div>
10	17	Vout	5V output to actuator's Potentiometer. Current max. 20mA.
11	18	G	GND

Remarks:

- (1) For port 5 6 12 13, the recommended cross-sectional area of each copper wire is 0.5mm² ~ 3.3mm² (20AWG ~ 12AWG)
- (2) For port 9 ~ 11, 16 ~ 18, the recommended cross-sectional area of each copper wire is 0.2mm² ~ 0.83mm² (24AWG ~ 18AWG).
- (3) For single actuator mode, please use only terminals 5 ~ 11.

4. Control input / output

The circuit prepared by the customer

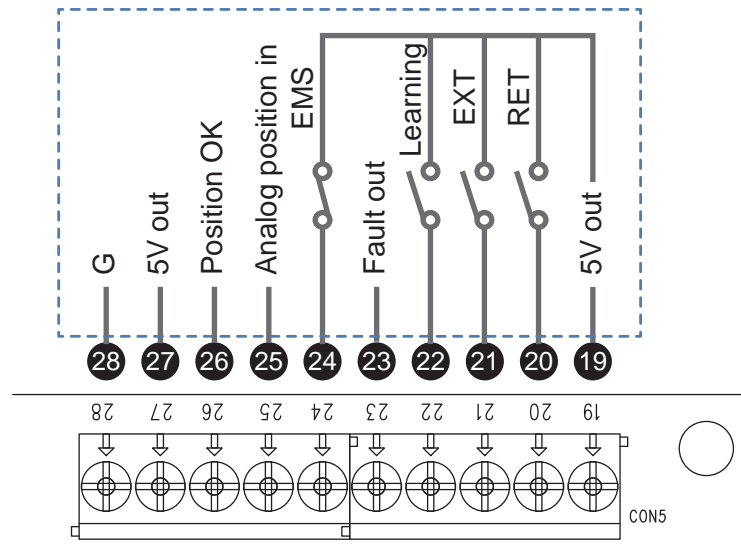

Port	Definition	Description
19	5V out	<ul style="list-style-type: none"> 5V output to the switch
20	RET	<ul style="list-style-type: none"> 'Retraction' signal input. Can use 5V of terminal 19 or external 5V power source. Actuator retracts when switch on
21	EXT	<ul style="list-style-type: none"> 'Extension' signal input. Can use 5V of terminal 19 or external 5V power source. Actuator extends when switch on
22	Learning	<ul style="list-style-type: none"> 'Learning' signal input. Can use 5V of terminal 19 or external 5V power source Triggered after switching on for > 2.0 seconds, the system will automatically learn the stroke of the actuators (see Parameter Setting and Test Run part 2)
23	Fault out	<ul style="list-style-type: none"> Error signal output Output 5V signal when overcurrent or lose the feedback signal of the actuator.
24	EMS	<ul style="list-style-type: none"> Input signal for emergency stop switch (Normally Closed) For customer to install emergency stop switch between terminals 19 and 24 To use this function, the JP1 jumper must be removed.
25	Analog position in	<ul style="list-style-type: none"> Analog signal (0~5V) to run the actuator to the specified position. (Evenly distribute 0~5V to the full stroke defined by the software limit switches.) The control signal can be generated using an external power source or using the 5V at terminal 27 via a potentiometer. It is forbidden to input PWM signal.
26	Position OK	<ul style="list-style-type: none"> In-position signal output When using the position input mode, the actuator will output a signal (5V) after reaching the specified position (according to terminal 25 input).
27	5V out	<ul style="list-style-type: none"> 5V power supply to the position input mode of control circuit
28	G	<ul style="list-style-type: none"> GND When using the position input mode, the GND of the power source must be connected here.

Remarks: For port 19 ~ 28, the recommended cross-sectional area of each copper wire is 0.2mm² ~ 0.83mm² (24AWG ~ 18AWG).

Parameter Setting and Test Run



- For safety and correct setting, please confirm that each actuator and all necessary control input/output terminals are connected properly before turning on the input power.
- Please confirm the actuator specification before setting.
- Re-learning is required after each parameter adjustment (if there is no positioning sensor, re-learning is not required).
- The factory default position of DIP switch are all 0.
- If an emergency stop switch is installed, normal operation is possible only when the circuit is closed.
- The temperature of the heat sinks cannot exceed 55°C. Overheating will activate the protection function and render it inoperable.
- If the selected control mode is "position input" (see section 1.1), the actuator must be equipped with positioning feedback function (Hall sensors or potentiometer).
- If the actuators have no positioning sensor, they must have limit switches that can cut off the power and stop by themselves, otherwise there is a high risk of damage to CI72.
- If 2 actuators are selected and without any positioning sensor, the control board only provides join-motion without synchronization.

1. Parameter setting

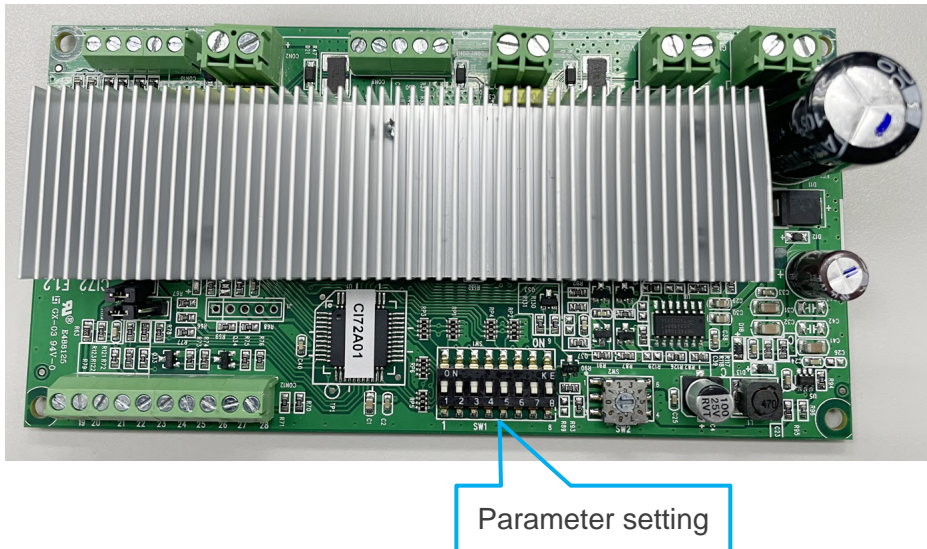





1.1 Control input mode

Parameters	Set	DIP switch
Switch control mode	0	
Position input mode	1	





1.2 Number of actuators to control

Parameters	Set	DIP switch
2 x Actuator	0	
1 x Actuator	1	

1.3 Types of actuator positioning

Parameters	Set	DIP switch
With dual Hall effect sensors	00	
With single Hall effect sensor	01	
With potentiometer (POT)	10	
Without positioning sensor	11	





1.4 Software stroke limit setting

Parameters		Set	DIP switch
With Hall effect sensor	With potentiometer		
Set the limit position at 40 pulses before both mechanical limits.	Set the limit position at 2% of the full stroke before both mechanical limits.	00	
Set the limit position at 20 pulses before both mechanical limits.	Set the limit position at 1% of the full stroke before both mechanical limits.	01	
Set the limit position at 10 pulses before both mechanical limits.	Set the limit position at 0.5% of the full stroke before both mechanical limits.	10	
No software limit (only selectable under the actuator with physical limit switches).	No software limit (only selectable under the actuator with physical limit switch).	11	

Remarks: Please refer to the actuator's Data Sheet for the relationship between the counts of Hall sensor pulses and the stroke.

1.5 Soft start/stop ramp setting

- This parameter is used to set the time of soft start and stop.
- For setting value > 00, it will show soft start when starting at any position within the full stroke range.
- If the position input mode is selected, it has soft stop function at any position within the full stroke range; However, if the switch control mode is selected, the soft stop function is only valid before both ends of the stroke, and there is no soft stop in the middle.

Parameters	Set	DIP switch
0 second (No soft start / stop)	00	
0.5 seconds	01	
1.0 seconds	10	
1.5 seconds	11	

1.6 Over-current protection setting

(It is recommended to use the typical full load current in the actuator data sheet plus 20% as the set value.)

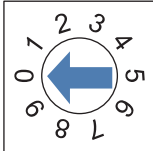
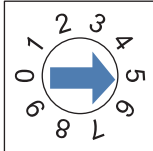
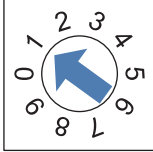
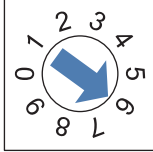
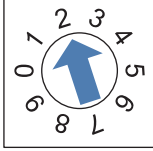
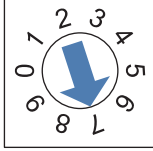
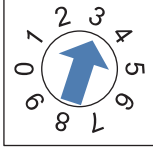
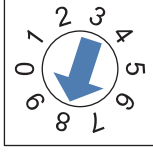
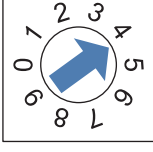
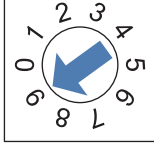

Over-current protection setting

Parameters	Set	Rotary switch	Parameters	Set	Rotary switch
2.0A	0		10.0A	5	
3.0A	1		12.5A	6	
4.0A	2		15.0A	7	
6.0A	3		20.0A	8	
8.0A	4		25.0A	9	

Remarks: Factory setting value is 0

2. Learning for actuators stroke



- The learning mode must be carried out under no load.
- If the actuator has no positioning sensor, there is no need to learn. Please test run directly (see section 3).
- For setting before first learning, it is recommended to set the software stroke limit and soft start/stop parameters to 00 respectively.

- Step 1. After the setting is completed, turn on terminal 22 (Learning) for more than 2.0 seconds to trigger, and the system will automatically learn the actuator stroke.
- Step 2. During learning: Actuator retracts to mechanically lower limit from any position → Extend to the mechanically upper limit → Retract to the starting position ⁽¹⁾
- Step 3. After learning, please check the default starting position of the actuator, and adjust the software limit parameters according to the situation (see section 1.4).
- Step 4. Re-learn after adjusting the parameters, try different parameters to tune out the best effective stroke.

Note (1)

- In switch control mode (see section 1.1), the starting position is the selected software lower limit position. In position input mode and port 25 (see Interface Guide part 4) is connected with position input, the starting position is the specified position by the input signal.
- If port 25 is floating in position input mode, the starting position is the selected software upper limit position.

3. Test run

- Step 1. Test running the full stroke
- Step 2. Set soft start/stop parameter according to requirements (see section 1.5).
- Step 3. Test run after adding appropriate load to confirm the best parameter settings.



The speed of actuators controlled by C172 will be lower than the typical values stated in the actuator's data sheet. The maximum speed loss is up to 25%.

Ordering Key

CI72 - 0

Mounting

0: PCBA only
R: With DIN rail holder

Certifications

CI72 controller is compliant with the following regulations, in terms of the essential conformity requirements of EMC Directive of 2014/30/EU.

Emission	Immunity
EN IEC 61000-6-3:2021 IEC 61000-6-3:2020	EN IEC 61000-6-1:2019 IEC 61000-6-31:2016

Terms of Use

The user is responsible for application suitability of Moteck products. As ongoing improvement process continues, products listed on the Moteck website are subject to change without prior notice. Moteck reserves the right to terminate the sales or remove any product displayed on the website, or listed in its catalogues.

MOTECK[®]
www.moteck.com